

AirJet

goes below the surface

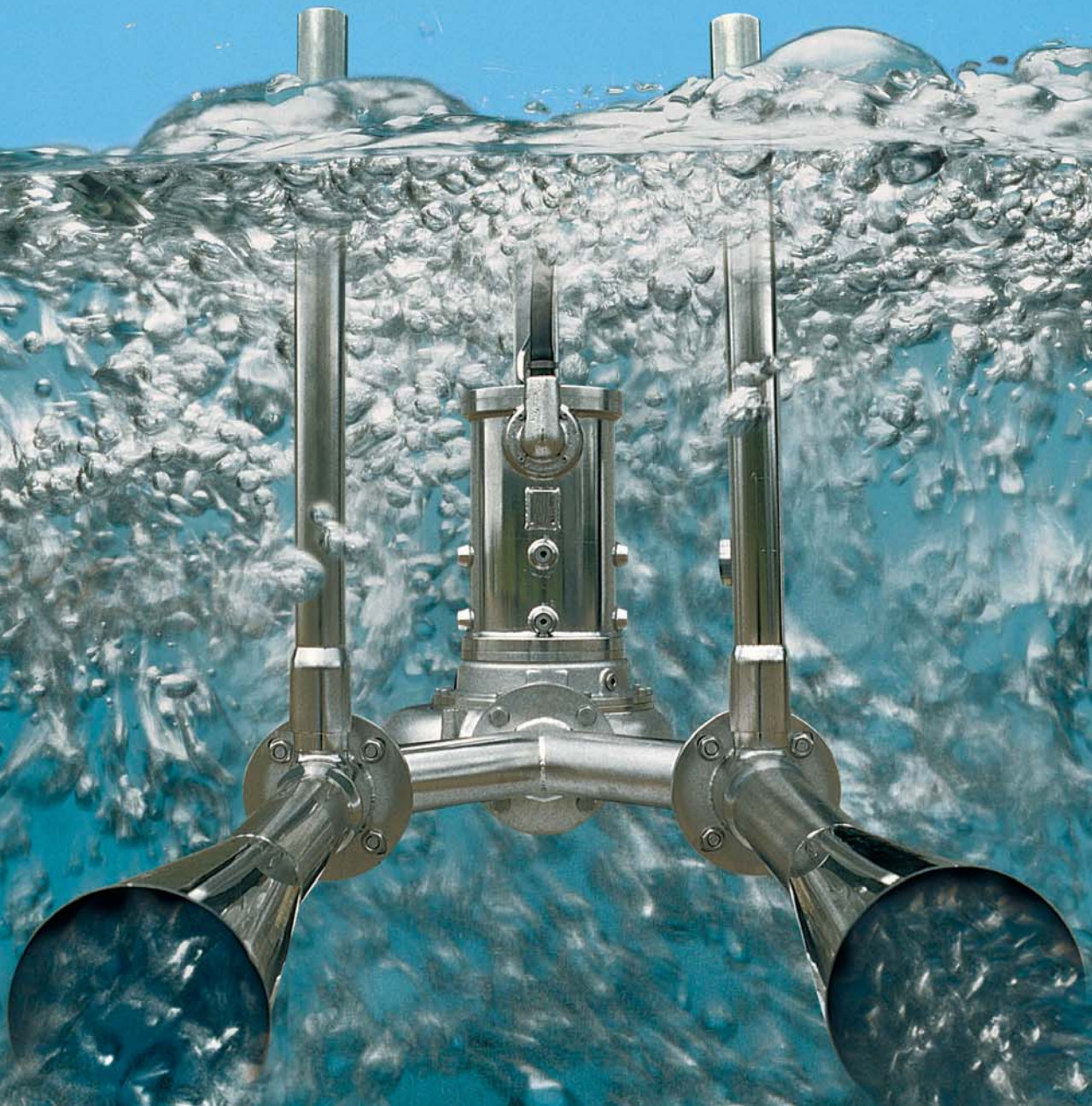

LANDIA AIRJET

THE ANSWER TO YOUR

AERATION REQUIREMENTS

Landia[®]

AirJet - systems to aerate and mix difficult mediums when treating sewage, storm water, industrial effluents and agricultural waste

Unique benefits

The benefits of the Landia AirJet aeration and mixing systems are created by the unique concept of combining a highly efficient air ejector with chopper pumps, and may also be used in conjunction with supplementary mixing systems, for optimum oxygen transfer rate.

As a world leader, Landia offers below surface aeration and mixing technology combined with chopper pumps. Combining chopper pump aeration systems with Landia submersible mixers provides the most beneficial approach to energy efficient and customized solutions even when treating the most difficult mediums.

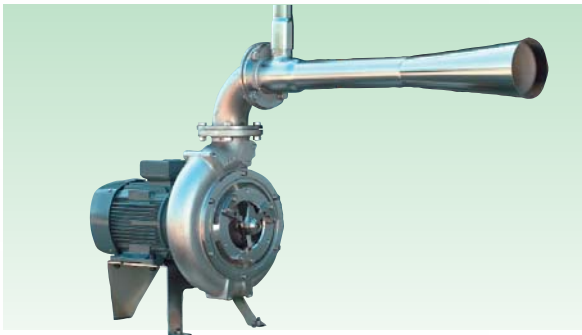

Externally mounted AirJet
For above-ground tanks

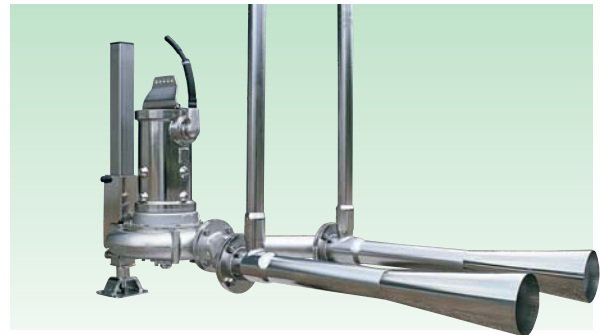

Submersible AirJet
Guide rail mounted, horizontally and vertically adjustable

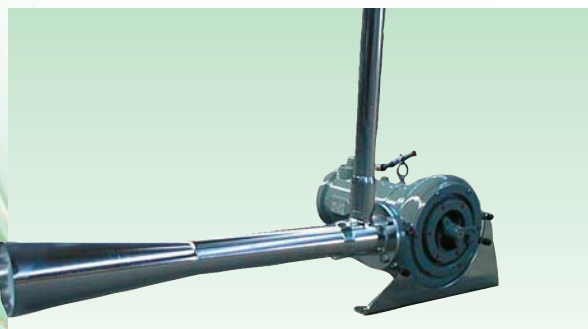

Submersible AirJet
Free standing on bottom of tank or lagoon



Floating AirJet
Suspended on pontoons, suitable for lagoons adjusting to liquid levels

Our customers choose Landia AirJet systems due to their numerous benefits

- Easy to install, even in flooded tanks
- Ideal for operation where liquid levels vary
- Self-aspirating, no need for compressed air supply
- Low investment stand-by aeration capacity during peak periods of oxygen demand
- Vigorous mixing capabilities improving oxygen transfer and preventing sedimentation
- Non-clogging aeration system capable of handling liquids with high dry matter content or coarse, unscreened dry matter particles
- Chopper pumps and equipment available in solid stainless steel for aggressive liquids
- Low noise level compared to other systems
- Odor reduction by preventing septicity

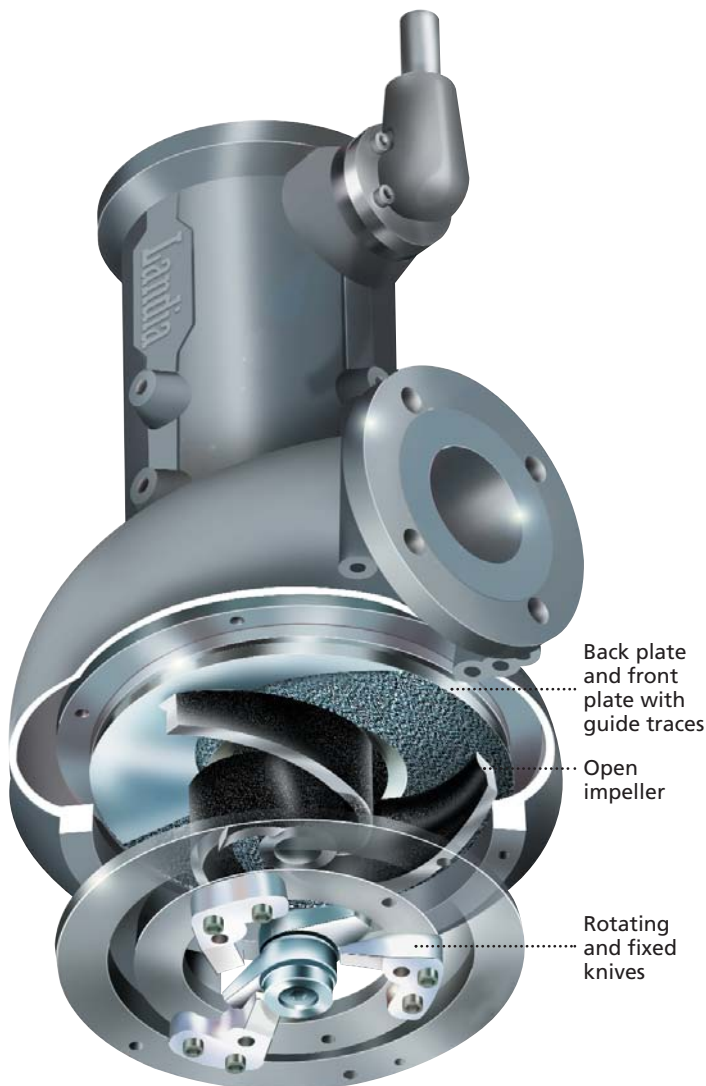

The advantages of combining chopper pumps with venturi ejectors

Rotating and fixed knives in front of the pump inlet ensure dry matter particles are chopped before they enter the pump and the diffuser of the aerator. This prevents clogging of the pump inlet and outlet, as well as the ejector.

Open impeller prevents dry matter particles from being "caught" in the pump.

Back plate and front plate with guide traces enhance transport of dry matter particles to the pump outlet and prevent build up of dry matter around the sealing system.

Organic dry matter is chopped into smaller particles, thus improving aerobic digestion and the process of reducing odors and BOD levels.

The function of the ejector

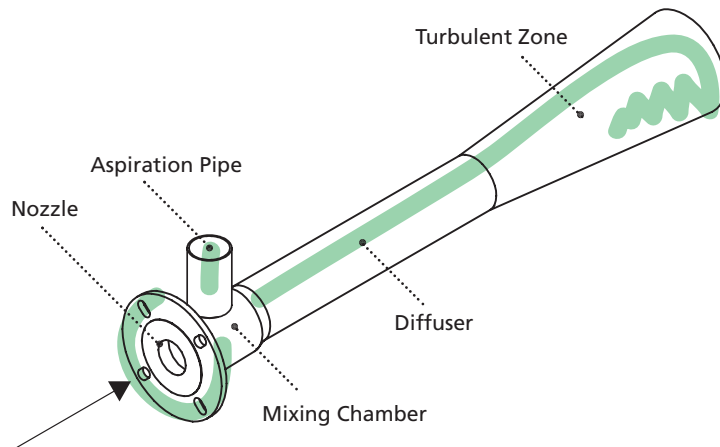

The liquid is pumped through the nozzle into the mixing chamber. Passing through the nozzle, liquid velocity is increased remarkably. This creates a stable negative pressure resulting in the air being drawn through the aspiration pipe.

In the mixing chamber air and liquid are mixed thoroughly. This mixing is enhanced in the ejector's high turbulent zone after which the liquid/air mix is flushed out through the diffuser by means of the high pressure created by the pump.

AirJet product range and performances

Pumps: A comprehensive range of AirJet with chopper pumps from 4.9 to 48 HP rated motor power is available.

According to process and application requirements AirJets can be delivered with one or two ejectors.

Materials: All ejectors are in stainless steel. Chopper pumps can be delivered in solid stainless steel, cast iron, or combined versions.

Installation: Submersible AirJets can be mounted on a stainless steel guide rail system for adjustment of horizontal and vertical position of pump and to allow easy pump removal for inspection and maintenance.

Performance: Oxygen transfer rates according to SOTR (ANSI/ASCE 2-91) are up to 2.2 lbs O₂/kWh.

Complete technical data and performance documentation are available on request. Contact us for sizing and process optimized solutions to your application.

Landia's AirJet systems – recommended by satisfied customers

Hundreds of AirJet systems operate in numerous countries worldwide. They aerate and mix multiple liquids and sludges and efficiently match our customers' requirements in a great variety of situations. Landia has an extensive track record of widely different applications.

Here are just a few:



Dry-installed AirJets in jam factory effluent aeration tank



Dry-installed AirJet in tannery effluent aeration tank



Dry-installed AirJet in tannery effluent aeration tank



Submersible AirJets in leachate tank



Submersible AirJets in leachate tank

■ Landia's AirJet systems – recommended by satisfied customers



Submersible AirJets in paper industry effluent aeration tank

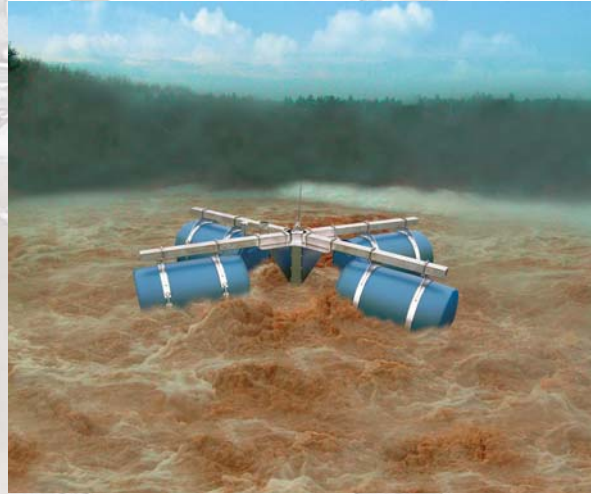

Floating AirJets in lagoon



Submersible AirJet for odor alleviation in abattoir wastewater



Combined system of submersible AirJet and submersible mixer in equalization tanks from vegetable processing industry



Submersible AirJet for agricultural waste



Submersible AirJet for agricultural waste

Landia's AirJet systems – recommended by satisfied customers



Storm water tank cleaning



Storm water tank cleaning

A complete range of submersible mixers and mixer/aerators

Landia's extensive range of submersible mixers and mixer/aerators add supplementary possibilities to optimize aeration efficiency and oxygen transfer. Sufficient mixing is achieved, solids remain suspended and thoroughly mixed with oxygen enriched effluent, thus enhancing aerobic digestion and improving process efficiency and final effluent quality.



Mixer/Aerator POdB-I



More than 70 years of experience,

offering solutions and systems for
the treatment of difficult mediums

Landia tackles the tasks which demand a specialist's expertise, and solves problems with e.g. pumping, mixing and aeration in domestic and industrial wastewater treatments, as well as numerous industrial processes.



Distributor:

CK14A.C15-010904

LANDIA A/S
DENMARK
ISO 9001

Landia®

Headquarter:
Landia A/S
Industrivej 2
DK-6940 Lem St.
Tel.: +45 97 34 12 44
Fax: +45 97 34 16 98
e-mail: info@landia.dk
www.landia.dk

Landia Inc.
111 Triangle Trade Drive
Cary, NC 27513
Phone: 919 466 0603
Fax: 919 460 1666
E-mail: info@landiainc.com
www.landainc.com