

## Slurry mixer/ aerator PODB

Landia self-aspirating mixer aerator with submersible electric motors from 7.5 to 18.5 kW. Highly effective system combining mixing and aeration. Elimination of odours. Complete mixing of slurry. Slurry spreading during vegetation period without burning of the plants.



- Non-clogging propeller, shaped to ensure maximum mixing and oxidation efficiency.
- Specially designed venturi system for air intake.
- Mechanical seal.
- Pressure tested waterproof motor casing, in protection class IP 68.
- Stator in insulation class F, thermal sensors in windings.
- Extensive range of accessories for mounting and operation.

# Slurry mixer/aerator PODB

## Performances and specifications:

Article no. (400V)	Motor size kW	Motor series	Current 3x400V amp	Motor rpm	Propeller rpm	Perform. approx. m <sup>3</sup> /h	Weight kg
1304307	7,5	132	15,5	1500	1500	1600	114
1304311	11,0	132	21,0	1500	1500	2250	121
1304315	15	160	28,5	1500	1500	3100	145
1304318	18,5	160	34,5	1500	1500	3800	179

Motor: 3-phased AC motor, 50 Hz, Voltage: 400V.

Self aspiration up to 2.5 meters below liquid surface. Air transfer decreases with immersion depth.

Functional drawing:

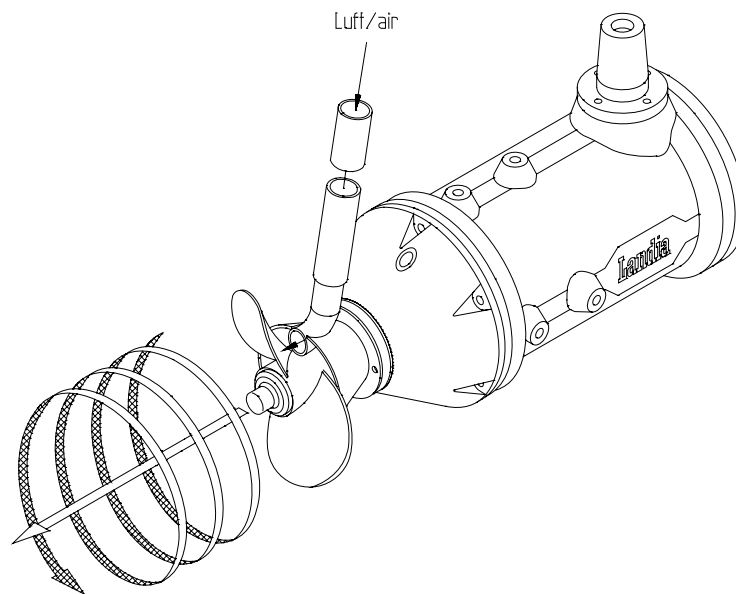

Ask for specification of accessories for installation.

The text and technical data given must not be reproduced partly or completely without permission from Landia A/S.  
We reserve the right to make technical alterations. 0303GB-980701

Head office: **Landia A/S**  
Industrivej 2  
DK-6940 Lem St.  
Tel.: +45 97 34 12 44  
Fax: +45 97 34 16 98  
e-mail: [info@landia.dk](mailto:info@landia.dk)  
[www.landia.dk](http://www.landia.dk)

UK-Branch: **Landia (UK) Ltd.**  
Waymills Industrial Estate  
Whitchurch, Shropshire SY13 1TT  
Tel.: 01948 661 200  
Fax: 01948 661 201  
Email: [info@landia.co.uk](mailto:info@landia.co.uk)  
[www.landia.co.uk](http://www.landia.co.uk)